



Please return the components to appropriately certified suppliers at the end of their service life!

# VARIOSAND - The extraordinary hourglass soldering kit

MADE IN EUROPE

Can be set from:

**1 minute**



**to 109 minutes**

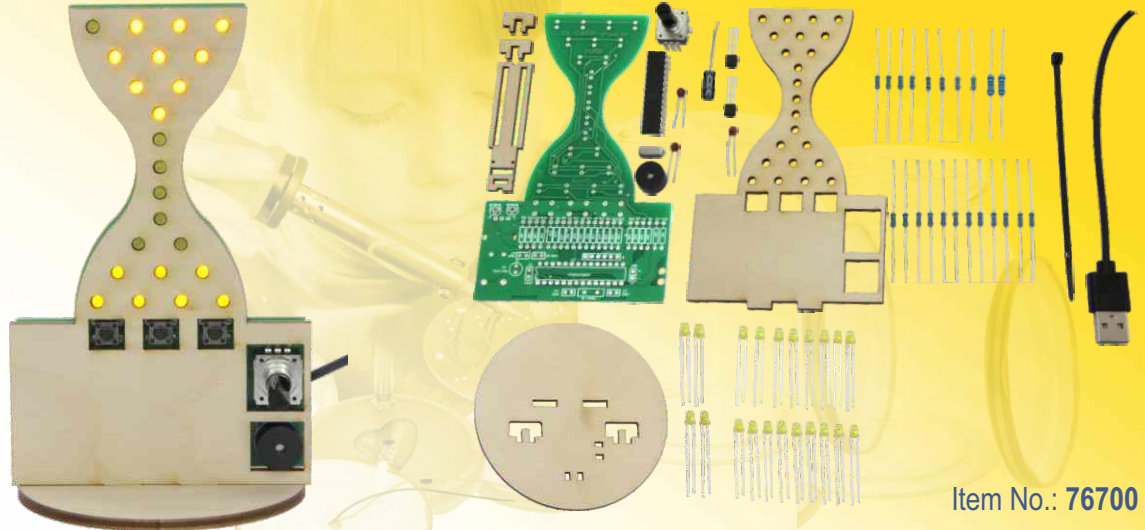

Item No.: 76700

## Important notes!



**!** For children and youngsters we recommend:  
Assembly and soldering should be supervised by an adult with soldering skills! **!**

### SAFETY NOTES:

- This kit is only intended to be USB powered.  
**Never connect the kit to 230 V mains voltage! This poses an absolute danger to life!**
- Keep these instructions for future reference! They contain important information.
- The soldering iron, the solder and the soldered parts become very hot. Be very careful!
- Always use a soldering mat when soldering! It prevents parts and the PCB from slipping.
- We recommend using a soldering iron holder to set the soldering iron down safely during use.

### ENVIRONMENTAL NOTES:

**Generally:** Please return electronic parts to certified disposal companies after use. These will ensure the parts are disposed of in compliance with the law. This is good for the environment and your part in actively protecting it.

## The VARIOSAND soldering kit - the extraordinary hourglass















The VARIOSAND circuit board kit is ideally suited for newcomers to soldering, all budding electronics engineers, hobby technicians and anyone who enjoys working with a soldering iron or soldering station. More than 60 parts are soldered on the "VARIOSAND" board, including an already programmed microprocessor. Once everything has been completely assembled, you'll have a wonderful programmable hourglass.







What is special about this hourglass is that a different time ("amount of sand" between 1 - 109 minutes) can be selected on each occasion. For instance, you can set VARIOSAND to 5 minutes for a soft-boiled egg or 10 minutes for a hard-boiled egg. When the time has expired, the "sand" has visually trickled down from the top to the bottom, the beeper sounds to tell you the egg is ready!

With VARIOSAND you can also store 3 separate times that you can then simply retrieve at the touch of a button. It might look something like this: On button "1" you store 15 minutes for the "crispy pizza" and on button "2" 4 minutes for "perfect tea-brewing time". Of course, you can decide for yourself which times you want to save. By the way, you can paint, varnish or decorate the wooden front or customise it as you wish. Let your imagination take over and turn VARIOSAND into a real eye-catcher.

This intelligent hourglass is powered by a power bank or directly from a USB port, such as a mobile phone charger. This eliminates the need for a costly extra battery. This is good for the environment and helps to make you more of a climate activist.

## VARIOSAND - The extraordinary hourglass

Parts list		Check the parts:	
Qty.	Part	Value / Designation	
1	PCB	76700	
23	3 mm LED (LED1-22)	yellow	
12	Resistor (R5-R16)	330 ohms	
2	Resistor (R2+R4)	1.5K ohms	
4	Resistor (R19-R22)	10K ohms	
2	Resistor (R1+R3)	4.7K ohms	
2	Resistor (R17+R18)	180 ohms	
1	Capacitor (C6)	10 uF/10V	
2	Capacitor (C4+C5)	10 nF/10V	
1	Capacitor (C1)	100 nF/10V	
2	Capacitor (C2+C3)	22 pF/10V	
3	Push buttons (SW2-SW4)	3301	
1	Processor (IC1)	ATMEGA328	
2	Transistor (T1+T2)	BC557B	
1	Quartz (Q1)	16MHz	

1	Piezo (J5)	12M	
1	Encoder (SW1)	Encoder	
1	USB connecting cable	40 cm	
1	Set of wooden parts	4 parts	
1	Bending aid for resistors		
1	Cable tie		
1	Wood glue		

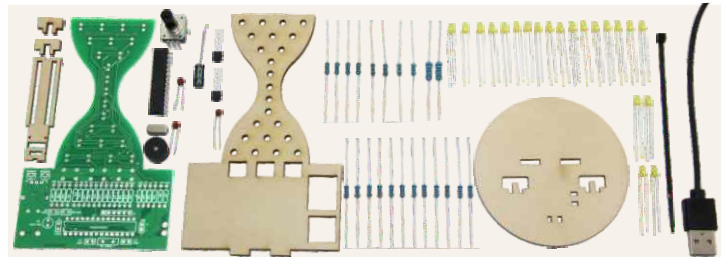





### You will also need:

Soldering iron, solder, side cutters, tweezers, powerbank (USB), possibly PCB assistant (an extra hand)

# ASSEMBLY INSTRUCTIONS

## Resistor colour code:

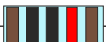
<b>330 ohms</b> orange orange black black brown 	<b>1.5K ohms</b> brown green black brown brown 	<b>180 ohms</b> brown grey black black brown 
<b>4.7K ohms</b> yellow violet black red brown 	<b>10K ohms</b> brown black black red brown 	

Tips from a pro  
on how to solder  
properly (QR):



## Preparation

Set out and sort all parts. This will make it easier for you to later identify the individual parts you will need during the steps.

And it doesn't hurt to tidy up your work space so you can quickly find all parts.

Set out your tools and switch on your soldering iron.

When using an adjustable soldering station/iron, we recommend a soldering temperature of about 320 - 340 degrees and a soldering tip about 2-3 mm wide.

Everything OK? Let's get started!



**A**

## Prepare resistors with the bending tool.

In order for **the small resistors** R1-R16 and R19-R22 to fit properly between the soldering points, the connecting wires must be bent exactly in the correct location. To make this easier, we have designed a simple yet functional bending tool. Simply place the resistors in the notch and bend the leads down straight along the wooden edge downwards into the notch.



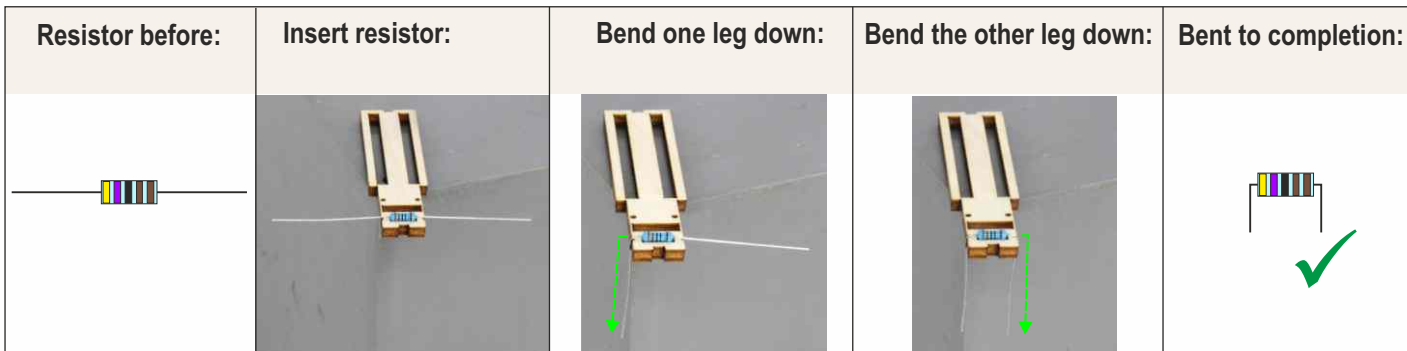

The part will now fit perfectly between the soldering points.

The connecting wires of the two somewhat larger resistors (180 Ohms) can be bent down directly on their bodies. Then they will fit perfectly between the soldering points.

**And this is how it is done:**



Resistors  
to bend:

- 12 x 
- 2 x 
- 4 x 
- 2 x 
- 2 x 

**B**

You will now need these parts:

10K ohms  
4 x  R19-R22

1 x PCB

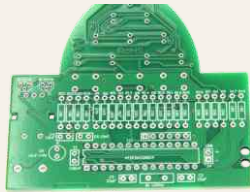

**Now the first resistors are soldered onto the PCB**

Place the PCB in front of you so that you can read the resistor values printed in white. Then place the 4 resistors individually one after the other on the board and solder them.

**Make sure that each component is as flat as possible on the board before soldering!**  
(see drawing below)

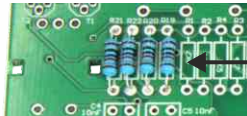

10K ohms  
4 x  R19-R22

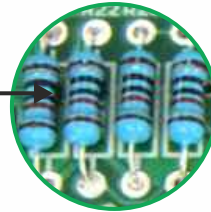

**Solder component flat on the PCB**

So that the component does not fall out again and lies flat on the circuit board, you can bend the wires outwards slightly.

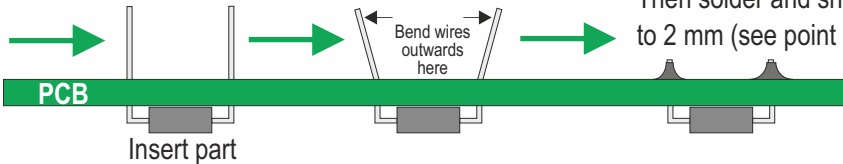
**C**

**Shorten any protruding wires.**

After soldering, cut off the protruding wires on the back, shorten to approx. 2 mm with the side cutter.

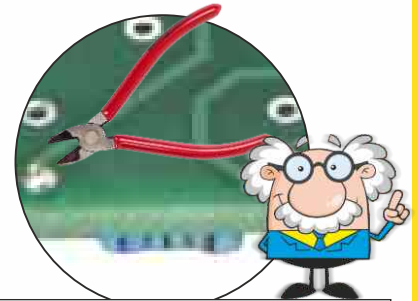

Trim here to 2 mm length:

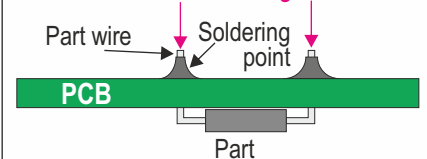

**D**

You will now need these parts:

2 x  1.5K ohms R2+R4

12 x  330 ohms R5 - R16

2 x  4.7K ohms R1+R3

2 x  180 ohms R17+R18

Now solder the remaining resistors one by one.

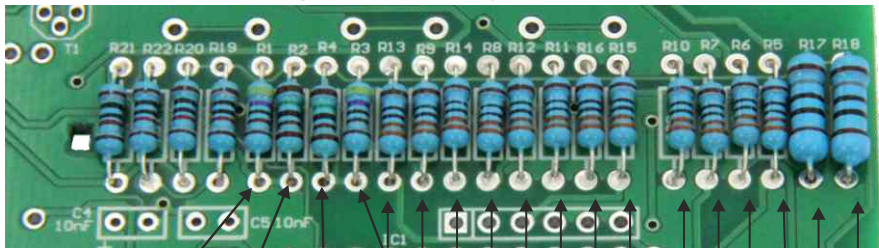

 4.7K ohms

 1.5K ohms

 4.7K ohms

 330 ohms

 180 ohms

And again trim the protruding wires.

After soldering, cut off the protruding wires on the back, shorten to approx. 2 mm with the side cutter.

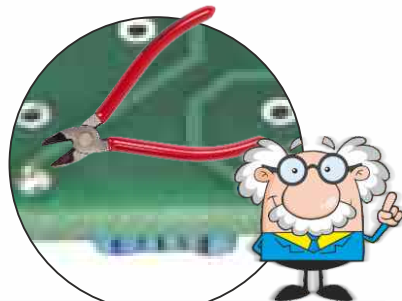

Trim here to 2 mm length:

Part wire  Soldering point

PCB

Part



**E**

You will now need the following parts:

2 x  $22\text{ pF}/10\text{V}$  C2+C3

1 x  $16\text{ MHz}$  Q1

Now solder on the two capacitors and afterwards the quartz...

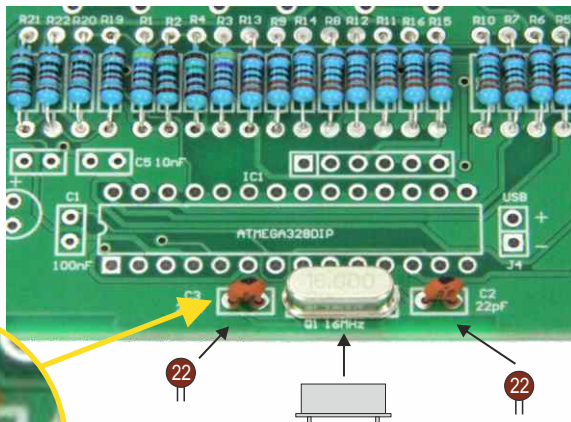

... and then trim the protruding wires.

After soldering, cut off the protruding wires on the back, shorten to approx. 2 mm with the side cutter.

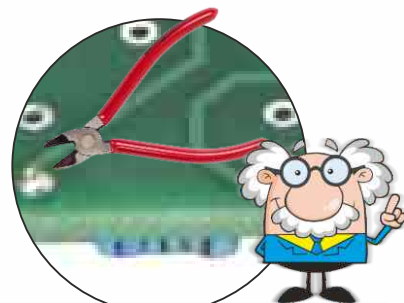

Trim here to 2 mm length:

Part wire Soldering point

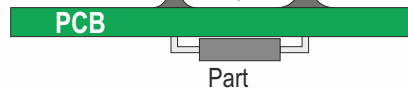

## F Now we come to the heart of the circuit: the processor!

- 1 To make it easier for the processor to slide between the soldering points, you can bend all the legs inwards a little. (Image 1)
- 2 When plugging in the processor, you must pay attention to its alignment. The processor has a notch (rounding), which must be oriented to the left when you insert it. In the magnified image below you can see the notch very well. (Image 2)
- 3 When you have plugged in the IC, turn the board over and check whether all 28 legs are visible in the soldering points (image 3). If no leg is visible in a soldering point, pull the IC out again, bend the leg carefully and plug the processor back in. Check again and then solder.

You will now need the following part:

1 x



IC1

Image 1

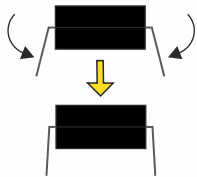

You can move the legs of the processor inwards. Then the IC slides better into the soldering points!

Image 2 VERY VERY IMPORTANT!

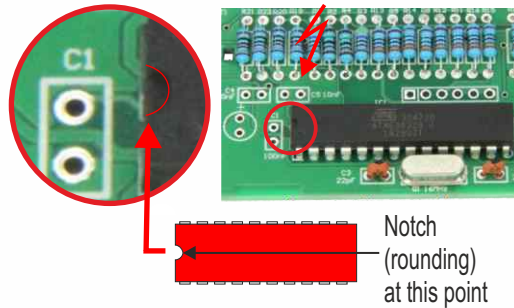
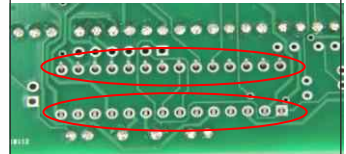

Image 3

Are all 28 feet visible?



**G**

Solder the capacitors C4 + C5 and then C1, trim solder wire to 2 mm.

You will now need the following parts:

2 x  $10\text{ nF}/10\text{V}$  C4+C5

1 x  $100\text{ nF}/10\text{V}$  C1

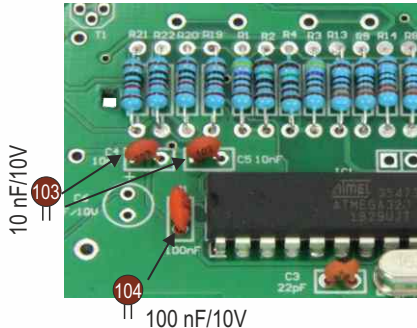
**H**

Solder on the transistors and capacitor. Bend the middle leg of the transistors slightly backwards (image 1), pay attention to the alignment (image 2) and solder the transistors. Pay attention to the polarity of capacitor C6, which is now soldered on. I.e. the leg marked "-" (minus) must be pushed into the correct soldering point. Then solder the capacitor in place and trim the soldering wires to 2 mm.

You will now need the following parts:

BC557B

T1+T2  
BC557B

$10\text{ }\mu\text{F}$   
 $10\text{ uF}/10\text{V}$

**Attention:**  
The legs of the transistors are very close together. Therefore please solder particularly carefully so that you do not create a short circuit between the legs.

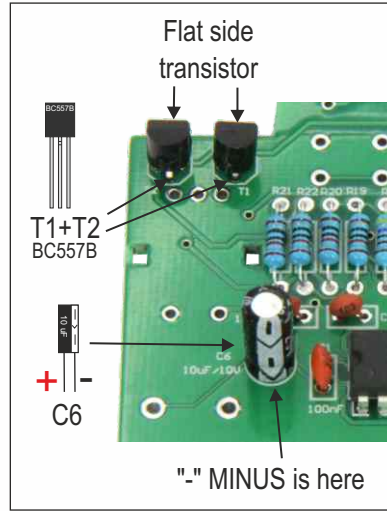
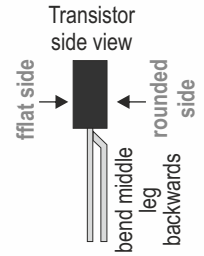
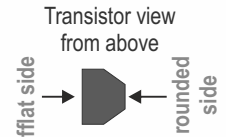
**Image 1****Image 2**

## I Solder on the buttons.

The buttons are soldered onto the on the **back**. Therefore, turn the PCB over and only then solder on the buttons.

You will now need the following parts:

3 x



SW2-SW4

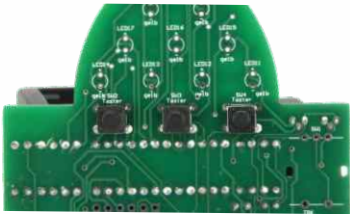

### TIP:

As the soldering legs of the buttons are thicker, you can increase the soldering temperature to 400°.

## J Now come the LEDs.

Solder on one LED after the other. It is essential that you observe the polarity of the LED. The longer leg is always PLUS "+" and has to be in the soldering point marked with "+". Also make sure that each **LED lies flat on the PCB** (see drawing below). This is very important to ensure that the wooden front can be fitted accurately later. It makes sense to solder the LEDs 1 / 4 / 14 / 11 first. Do not forget to trim the wires.

You will now need the following parts:

23 x



LED1-23

### Solder the LEDs flat on the PCB:

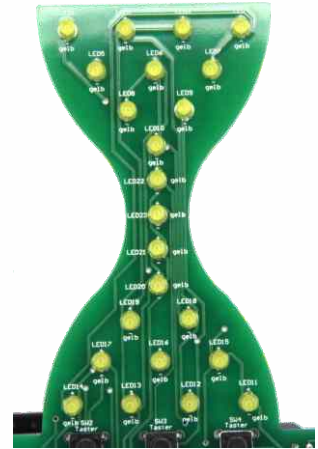
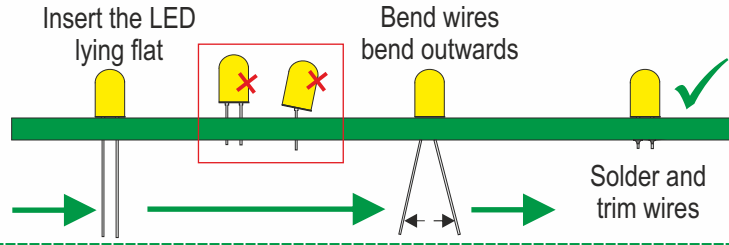

## K PIEZO and encoder.

Ensure that the polarity of the piezo is correct. You will find a "+" symbol on both the circuit board and the piezo. After soldering, remove the sticker from the piezo. Then solder on the encoder and trim the protruding legs.

You will now need the following parts:

1 x J1

1 x SW1

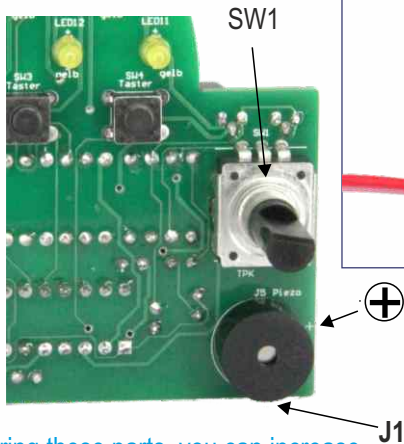

**TiP:** When soldering these parts, you can increase the temperature of the soldering iron slightly, to about 400°.

## L Solder the USB connection cable.

First thread both individual cables (red and pink/white) together approx. 1.5 cm through the two holes. To solder, push the strand of each cable through soldering point and solder from the other side. **The red cable to "+" and the pink or white cable to "-".**

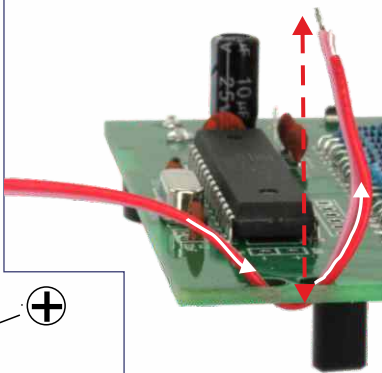

**Cable length: approx. 1.5 cm (red arrow)**

**It is essential to observe the wire colour:**

**Red wire "-"**

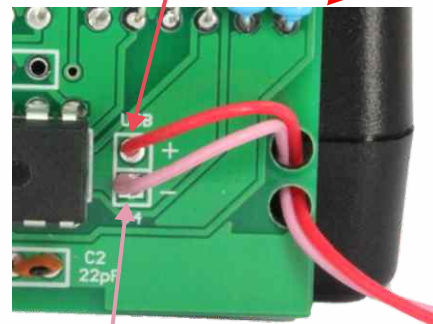

**Red or white wire "+"**

## M Mount the front cover.

Before attaching the wooden front, double-check that all the protruding wires have been shortened to 2 mm.

Then push the front cover over the LEDs. Align the LEDs if necessary!

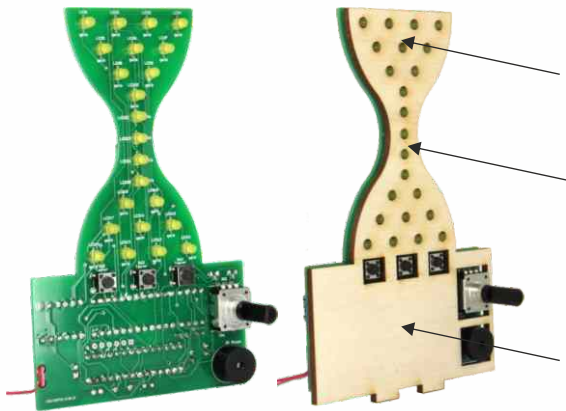

## N Glue the hourglass to the base plate.

Apply a little wood glue to the areas marked in red and then press the hourglass onto the the base plate.

Then wait approx. 10 minutes until the glue has dried.

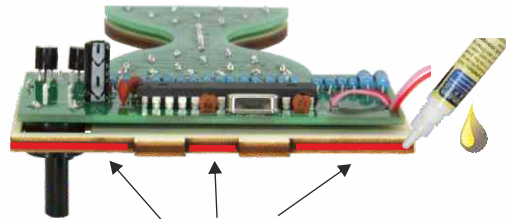

Gluing surface: —

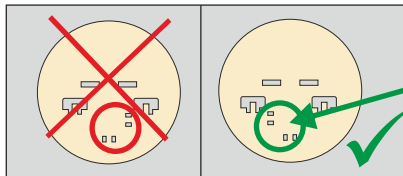

Pay attention to the alignment of the base plate!

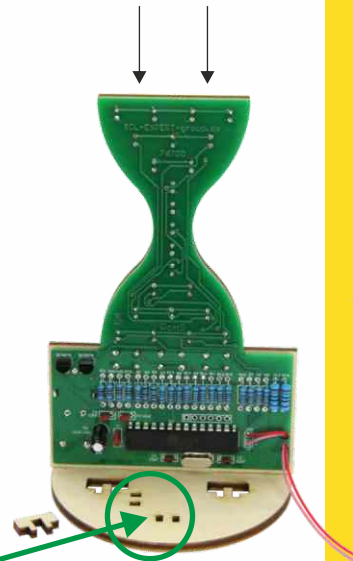

10 minutes



## Mount the cable strain relief.

Fasten the cable tie tightly around the cable with approx. **1.5 cm** distance to the cable casing (see image 1). Trim the protruding piece of the cable tie with the side cutters. Then apply wood glue to the first cable fixings (image 2), slide it over the cable and press it into the base. Allow to dry for 5 minutes and then glue in the second fixation (image 3). Now let the glue allow to dry for approx. 10 minutes.

You will now need the following parts:

1 x  Cable tie 2 x 

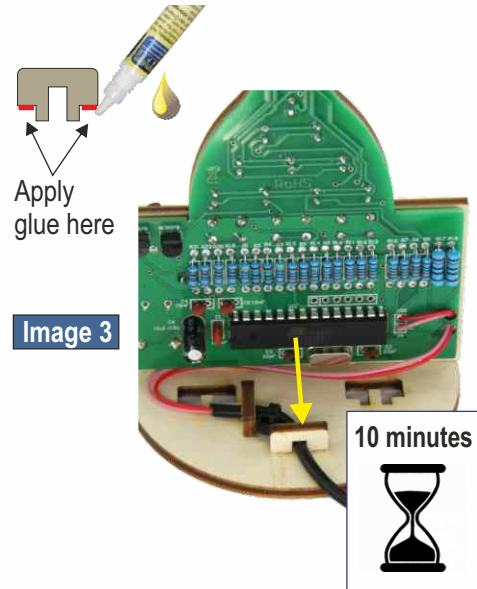
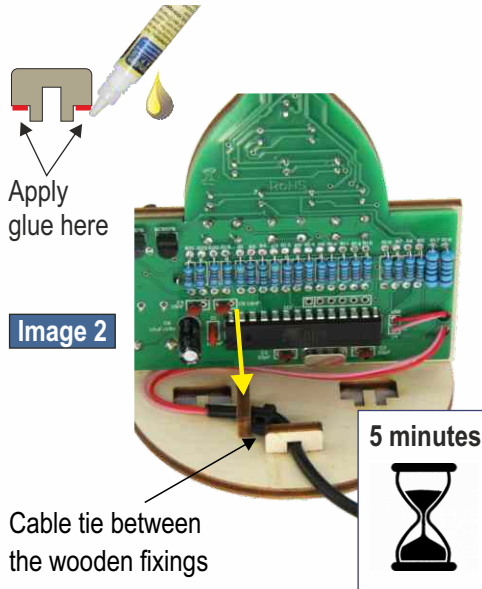
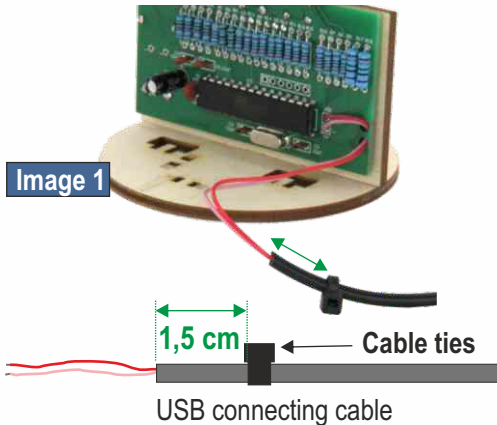

## **P** VISUAL INSPECTION:

Just sit back and relax and let your mind wander a little. When you are fully chilled out, take another look at the the assembly instructions from the beginning and check whether you have done everything as described in the instructions. Pay particular attention that no short circuits have occurred and that the values of the resistors, etc. are correct.

Everything OK?  
WELL DONE!!



Now we can move on with Q:

**Q** Now connect the USB cable of the VARIOSAND hourglass to a USB port (e.g. power bank or mobile phone power supply). Now all the LEDs should trickle down from the top like the sand in a real hourglass. If this does not happen, the following list may help you to check possible causes:

Malfunction:	Troubleshooting:
Not working, nothing happens!	<ul style="list-style-type: none"><li>■ Check all solder joints on the processor for short circuits</li><li>■ USB cable correctly soldered with the correct polarity? ■ Powerbank fully charged? ■ Check transistors for short circuit</li></ul>
Individual LEDs do not light up	<ul style="list-style-type: none"><li>■ Re-solder the solder joints of the malfunctioning LED with some solder.</li><li>■ Check the solder joints of the resistors ■ Is the LED soldered the right way around? Is the "-" on the negative? If necessary, desolder and turn 180 degrees.</li></ul>
No time change when turning the rotary wheel	<ul style="list-style-type: none"><li>■ Check and re-solder all solder joints on the encoder</li></ul>
There is no signal after the time has expired	<ul style="list-style-type: none"><li>■ Check the piezo (buzzer) for polarity and re-solder the soldered joints.</li></ul>
Preset time cannot be programmed	<ul style="list-style-type: none"><li>■ Check and re-solder the solder joints of all the buttons.</li></ul>



## Manual time setting

When you connect the hourglass to a USB port (power bank or mobile phone charging adapter), the programme starts and the "sand" starts trickling from top to bottom. After that, the middle LED starts to light up permanently, telling us it is ready for use.

If the button on the rotary encoder is now held down for approx. 2 seconds, the middle LED starts to flash briefly. Then the lower right LED lights up. If the rotary encoder is now turned clockwise, more and more LEDs will be switched on.

In the lower section of VARIOSAND (highlighted in blue in the example below), each illuminated LED stands for 1 minute and in the upper section (highlighted in green in the example below), each illuminated LED stands for 10 minutes. Both numbers together indicate the total time set. In the following, you will see 3 examples that illustrate how you can read the time:

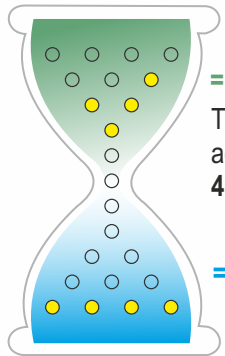

= 40 minutes

The total time is calculated by adding the two sections, i.e.:  
**40 mins + 4 mins = 44 minutes**

= 4 minutes

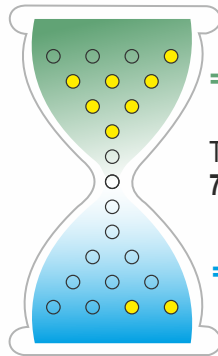

= 70 minutes

The total time is:  
**72 mins**

= 2 minutes

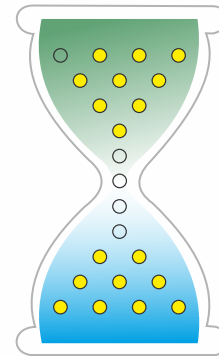

= 90 minutes

The total time is:  
**99 mins.**

= 9 minutes



If you turn the rotary encoder anti-clockwise, e.g. to correct the time, the LEDs are individually switched off again. Once you have set the desired time, you confirm this by briefly pressing the head of the rotary encoder.

All the upper LEDs now start to light up and, depending on the time set, the "sand" will gradually start to trickle down from the top to the bottom. When all the "sand" has reached the lower area and the time has expired, the buzzer sounds. You can switch it off by pressing any button or switch.

### **The memory buttons**

VARIOSAND can store a total of three freely selectable times, which can then be retrieved simply by pressing a button. And this is how it works:

#### **Programme the desired time:**

Use the rotary encoder to set the desired time and then press one of the three buttons under which you want to save the time. The LEDs start flashing briefly and the desired time is stored under the pressed button. The flashing LEDs go out and the middle LED lights up: the desired time has been permanently stored. If you want to change the stored time, repeat the procedure. The new programmed time overwrites the previous one.

And this is how  
you can programme  
the desired time



### Retrieve desired time

The set time is accessed by pressing the corresponding button. The programme starts automatically.

### Stopping the timer before it's up

Briefly pressing the rotary encoder button interrupts the programme sequence and VARIOSAND automatically returns to the switch-on state.

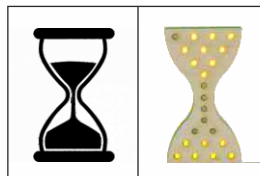
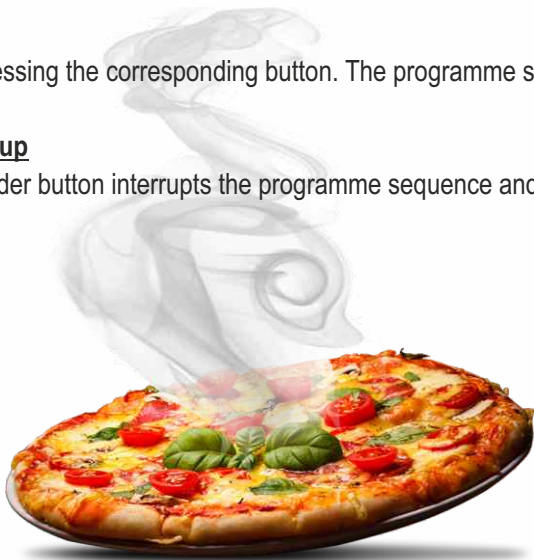

And when the eggs are boiled, the pizza is ready, the smell of cake is wafting through your home and you no longer need VARIOSAND, unplug it and keep it safe and dry for the next time.

Hier geht es zur Anleitung:



Click here for the instructions:



Cliquez ici pour les instructions:



Klik hier voor de instructies:



**Other great SOL-EXPERT group soldering kits:**

**Binary Clock soldering kit**

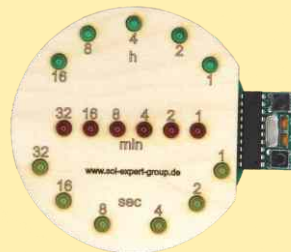

Shows the time digitally!

Item no.: 76334

**TrainYourBrain soldering kit**

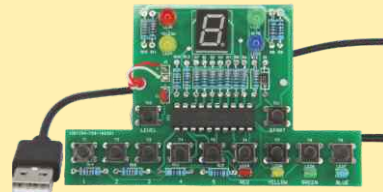

Keep your brain fit!

Item no.: 79300

**SOL-EXPERT group, C.Repky**

Mehlisstrasse 19 - D-88255 Baidt

Tel.: +49 (0)7502 - 94115-0 - Fax: +49 (0)7502 - 94115-99

info@sol-expert-group.de

**www.sol-expert-group.de**

*Errors and changes reserved  
July 2021 / Christian Repky ©*

